

**TYPES**

- Type **A**: without sealing washers
- Type **B**: with sealing washers

**Main specifications**

- AISI CF-8 stainless steel
- Sandblasted matte finish
- Sleeve bearing
- Plastic (PTFE)
- Carriage bolt DIN 603
- Stainless steel
- Cap nuts DIN 917 / Washers
- Stainless steel
- Seals
- Sealing washers
- Plastic (Polyacetal POM)
- Spacer ring
- Silicon, 40 ... 60 Shore A



**FEATURES AND APPLICATIONS**

Two-way linear actuator connectors GN 132.15 are based on two-way connector clamps. The additionally provided mounting holes are used to connect to the drive key of a linear actuator. Bores with the designation **G** are equipped with sleeve bearings. With the screw locations **z**, the play of the guide bore d1 can be adjusted or the linear actuator connectors can be clamped after adjustment. Type B is equipped with seals at the screw locations. For quick clamping without tools, the cap nuts can be replaced by the adjustable hand levers GN 911.3 (see page ).

**ACCESSORY**

Adjustable Hand Levers GN 911.3 (see page ).

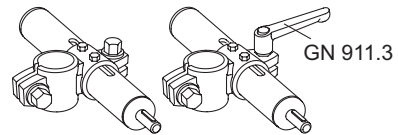

**GN 132.15-A**

**GN 132.15-B**

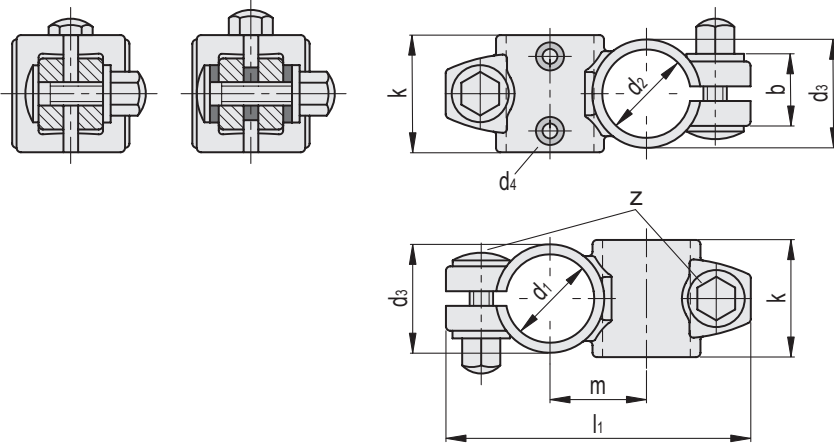

**GN 132.15-A**

Code	Description	d1 - d2 with sleeve bearing	d3	d4	b	k	l1	m	z	z Clamping kit	⚖️
GN.42881	GN 132.15-G30-B30-A-4	G 30 - B 30	37	M 4	22	40	104	33	M 8	GN 911.3-63 / GN 911.3-78	296
GN.42885	GN 132.15-G50-B50-A-4	G 50 - B 50	60	M 6	30	65	150	53	M 10	GN 911.3-78 / GN 911.3-92	970

**GN 132.15-B**

Code	Description	d1 - d2 with sleeve bearing	d3	d4	b	k	l1	m	z	z Clamping kit	⚖️
GN.42883	GN 132.15-G30-B30-B-4	G 30 - B 30	37	M 4	22	40	104	33	M 8	GN 911.3-63 / GN 911.3-78	296
GN.42887	GN 132.15-G50-B50-B-4	G 50 - B 50	60	M 6	30	65	150	53	M 10	GN 911.3-78 / GN 911.3-92	970

Tube connectors